

ESCOL ELECTRONIC HOBBY KITS

www.escol.com.my

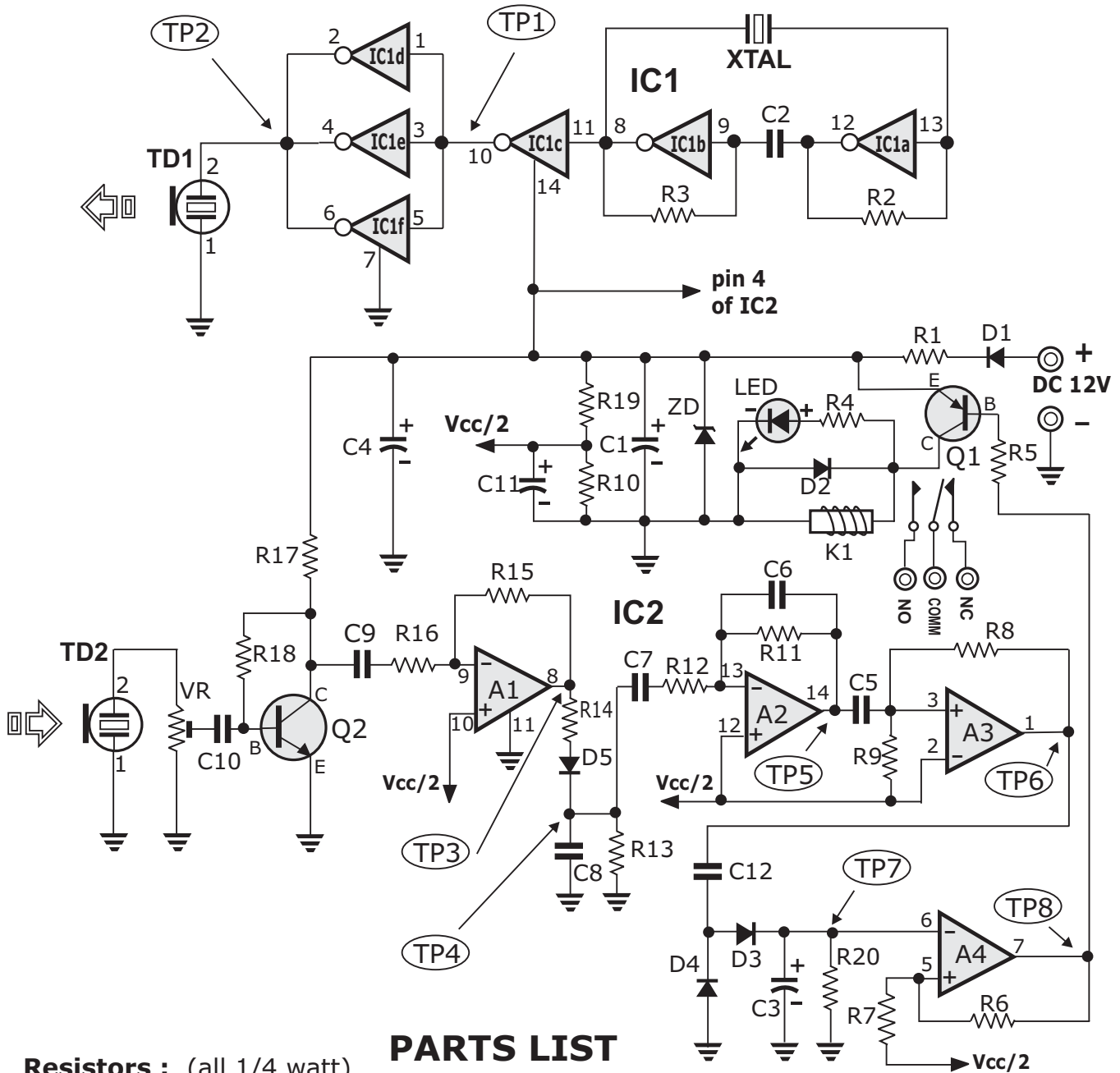

### PARTS LIST

#### Resistors : (all 1/4 watt)

- R1 ----- 33 Ω (orange-orange-black) [oren-oren-hit]
- R2, R3, R20 ----- 1M (brown-black-green) [cok-hit-hij]
- R4 ----- 1K (brown-black-red) [cok-hit-mer]
- R5, R10 ----- 6.8K (blue-grey-red) [biru-kelabu-mer]
- R6, R8, R11, R18 ----- 2.2M (red-red-green) [mer-mer-hij]
- R7, R9, R13 ----- 470 K (yel-violet-yel) [kun-ungu-kun]
- R12, R14, R16, R17, R19 -- 10K (brown-black-orange) [cok-hit-oren]
- R15 ----- 100K (brown-black-yel) [cok-hit-kun]
- J ----- jumper (bare wire)

#### Capacitors : (electrolytic)

- C1 --- 330 μF (min 16V)
- C3 --- 1 μF (min 10V)
- C4 --- 4.7 μF (min 16V)
- C11 -- 10 μF (min 6.3V)

#### Capacitors : (mylar or ceramic, min:16V)

- C2, C9, C10 -- 0.001 μF (#102 OR 1n)
- C5 ----- 0.01 μF (#103 OR 10n)
- C6 ----- 30 or 33 pF
- C7, C8, C12 --- 0.1 μF (#104 OR 100n)

**Semiconductors, etc. . . .**

- IC1** --- CMOS 4069 ( hex inverters)
- IC2** -- TL 084 (Quad operational amplifiers)
- Q1** --- 2SA 1015 (or other general purpose PNP transistor)
- Q2** --- 2SC 1815 or 945 (or other general purpose NPN transistor)
- D1, D2** --- 1N 400x (x = 1,2, ... ,7) (rectifier diodes)
- D3, D4, D5** --- 1N 4148 (or other general purpose switching diodes)
- ZD** --- Zener diode, 400 mW 13V
- VR** -- Trimmer pot (preset) 10 K $\Omega$
- K 1** -- Miniature relay. Coil = DC 12V (or 9V)
- LED** -- Light emitting diode. 5 mm
- XTAL** --- Tuning fork crystal, 40 KHz
- TD1** --- 40 KHz Ultrasonic transducer (transmitter)
- TD2** --- 40 KHz Ultrasonic transducer (receiver)

(NOTE : Transmitter & receiver can be identified by its part number.  
 40T = transmitter, 40R = receiver. If no part number found,  
 then the one with white paint mark is the transmitter TD1)

white paint mark (if no marking is found)

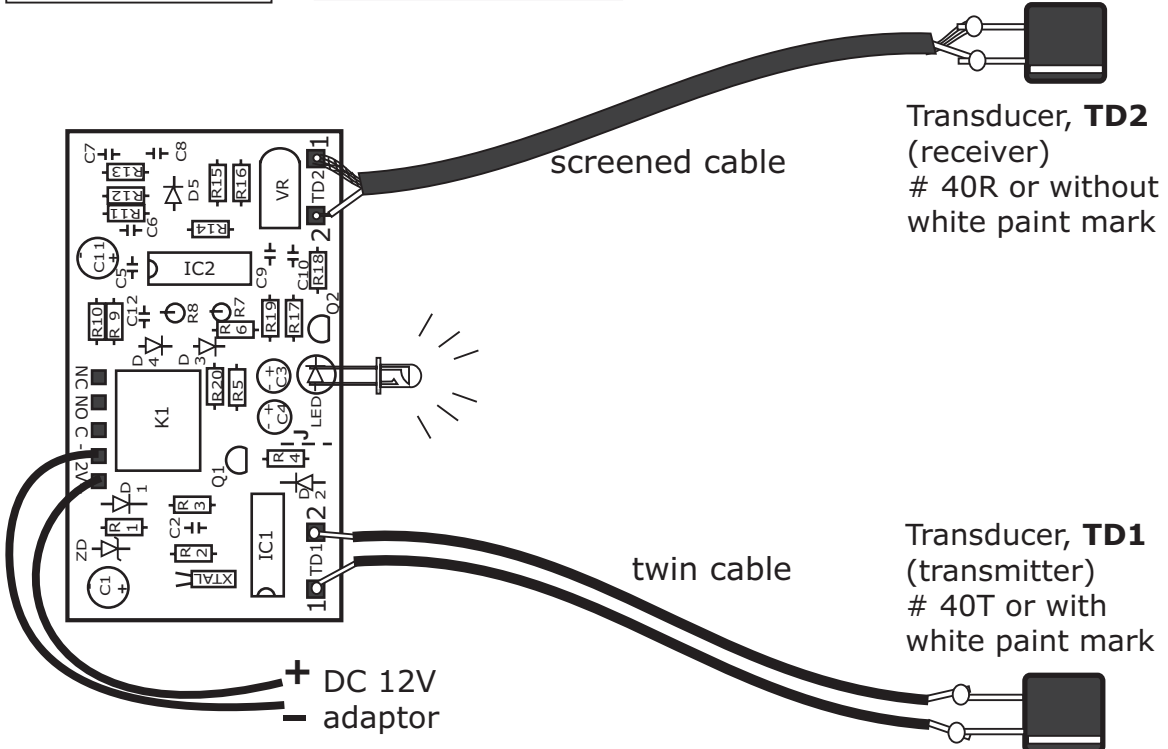
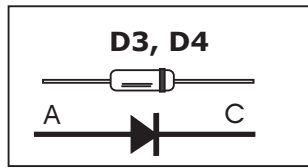
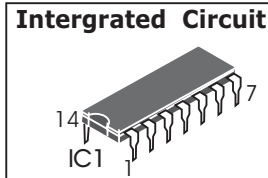
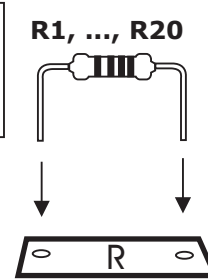
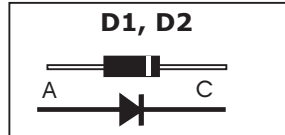
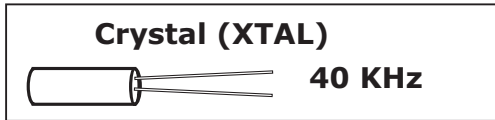
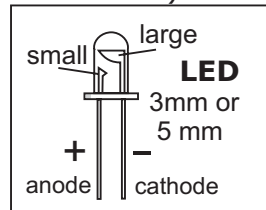
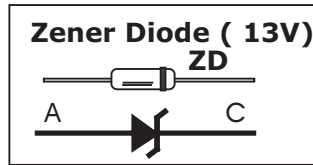
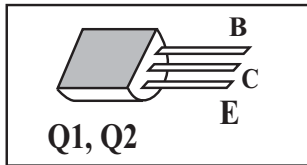
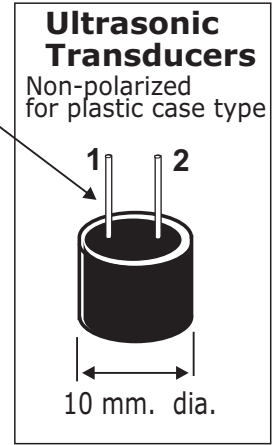

**APPLICATION :** 1) (to be used with door chime) To announce the arrival of guests or customers.  
2) as an add-on burglar/intruder detector to existing alarm system (see INSTALLATION for details)

**HOW IT WORKS :** The kit uses 40 KHz ultrasonic waves to detect moving objects. When a burglar or intruder enters the detection zone, the reflected waves changes its amplitude slightly. This change of amplitude cause the circuit to actuate a miniature relay for a few seconds..

### INSTALLATION:

- 1) the detector *should not be used* at places where interference from electric fans, insects & household pets are expected. It is not intended for outdoor use.
- 2) Do not place obstacles in front of the detector.

### TEST & ADJUSTMENT

- (1) Connect the detector to any DC adaptor (12V, @ 200mA min.).
- (2) Wave your hand in front of the transducers to simulate moving object. In response to this, the relay should activate promptly (& the LED lights up) for a few seconds.  
The LED & relay will remain ON until the motion stops.
- (3) Adjust VR to set appropriate level of sensitivity (depending on the environment where the detector is installed). Setting it too high will induce false alarm!

### PROSEDUR MENGUJI

- (1) Sambungkan bekalan kuasa DC 12V dari adaptor ke kit ES-15.
- (2) Laraskan pot penghalus (VR) hingga setengah pusingan daripada pusingan penuh.
- (3) Goyang-goyang tangan anda di hadapan transducer selaku objek yang bergerak. Litar ini sepatutnya memberi sambutan segera dengan menggerak geganti dan LED menyala beberapa saat.

### PEMASANGAN

- (1) Pengesan dicipta hanya untuk kegunaan dalaman sahaja.
- (2) Ia tidak boleh dipasang pada tempat-tempat yang terdapat banyak gangguan seperti angin yang kuat atau kipas.
- (3) Pengesan hendaklah diletakan ditempat yang jelas dikawasan jagaannya (tidak boleh menghadang didepan transducer)
- (4) Laraskan pot penghalus (VR) bagi mendapatkan paras kepekaan yang dikehendaki. Sekiranya berlaku tinggi, penggera palsu akan terjadi.

**用途:** (1) 可作顾客或访客到访报知器。  
(2) 防盗系统

### 工作原理:

本机之超声波发射器(TD1)不断发射40KHz之超声波, 反射回来之超声波 则由TD2接收, 若探测范围内有移动物体出现, 反射波之频率将会起变化, 频率的改变由电子线路检测并放大, 以推动继电器(RLY)及LED.

**安装:** (A) 本机只适合户内使用, 并远离强风, 电风扇, 昆虫, 宠物等出现的地方. 因风吹草动将引起错误警报.  
(B) 在超声波感应器(TD1 & TD2)之前不得摆放任何障碍物, 否则线路将无法正常工作.

### 调校:

先将本机接上电源(可用12V 200mA之过电器), 然后将可变电阻(VR)调到中点, 用手在感应器 (TD1 & TD2) 前挥动一下, 此时LED应亮起, 继电器启动 数秒钟, 若手不停挥动则LED将不断亮着, 继电器也一直保持ON的状态, 直到手停止挥动. 实际使用时, 灵敏度(VR)不宜调得过高, 否则会时常发生错误警报.

**Crystal oscillator buffered output**

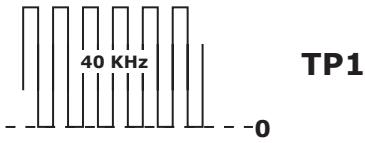

**Transducer driving signal**



**No moving object present**

**Moving object detected**

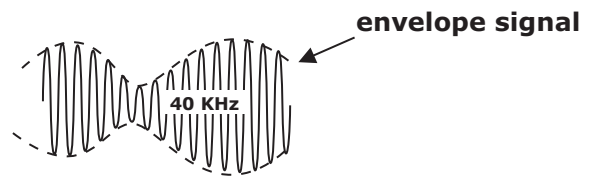
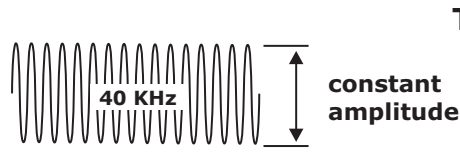

Reflected sound picked up by TD2 & amplified by Q2 & A1

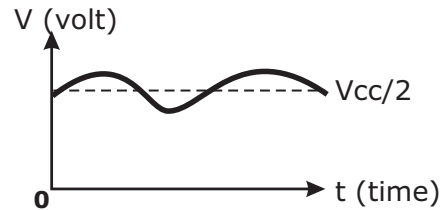
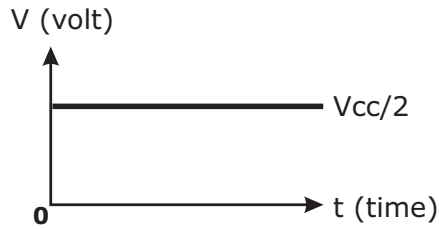

Original envelope signal as extracted by R14, D5, C8, R13

**NOTE** that the frequency of envelope signal is directly proportional to the speed of the moving object

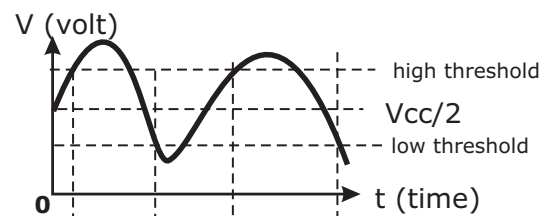
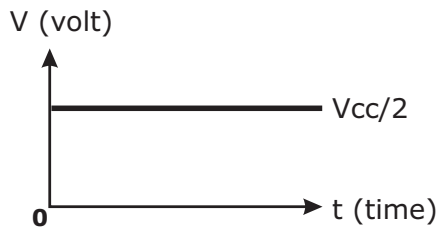

Envelope signal after amplification by A2

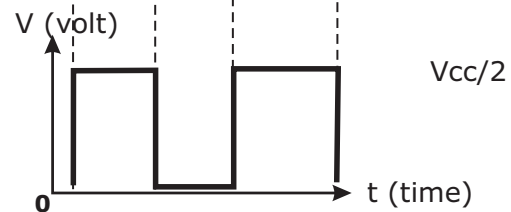
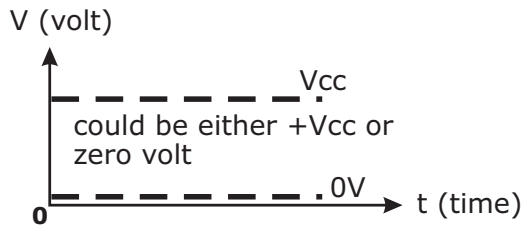

Envelope signal is converted to square wave by A3

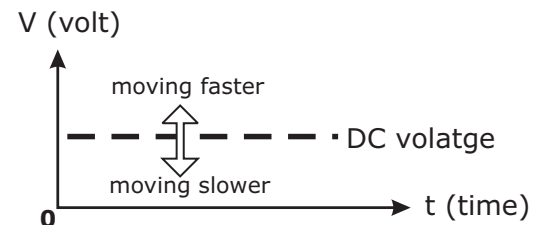
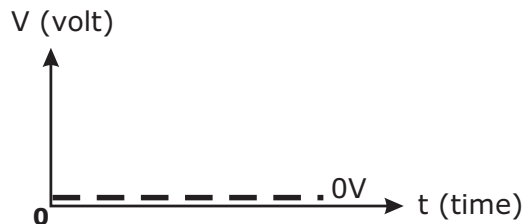

Envelope signal is converted to DC voltage by C12, D3, D4, C3 & R20  
The level of the DC voltage is directly proportional to the speed of the moving object which means that the voltage is **zero** if the object is **not moving**.