

Stereo Transmitters
BA1404 BA1404F

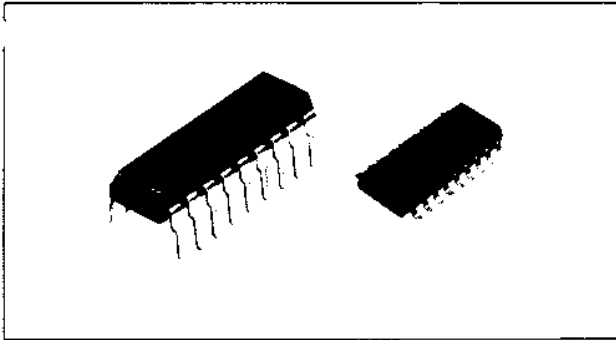

The BA1404 and BA1404F are monolithic FM stereo transmitters. The devices contain a stereo modulator, an FM modulator, and an RF amplifier. The stereo modulator creates a stereo composite signal (which consists of a main (L+R), sub (L-R), and pilot signals) from a 38 kHz quartz controlled frequency. The FM modulator oscillates a carrier in the FM broadcast band (76 to 108 MHz) and modulates it with the composite signal. The RF amplifier creates energy to emit the modulated FM signal. It also functions as a buffer for the FM modulator.

Features

1. Low-voltage, low-power design.
2. Stereo modulator, FM modulator, and transmitter implemented on a single chip.
3. Few external components required.
4. High separation (45 dB typ.).

Applications

FM stereo transmitters
 Wireless microphones

Dimensions (Unit: mm)

BA1404

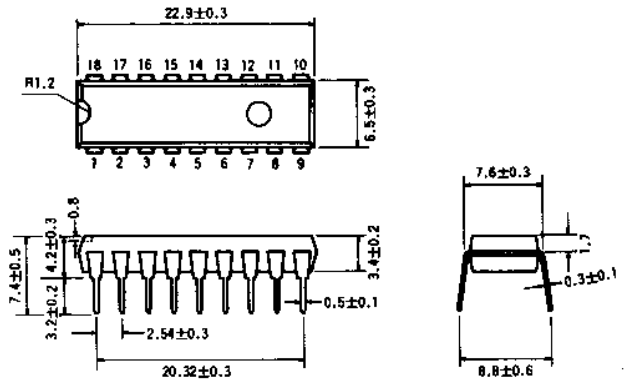

Fig. 1

BA1404F

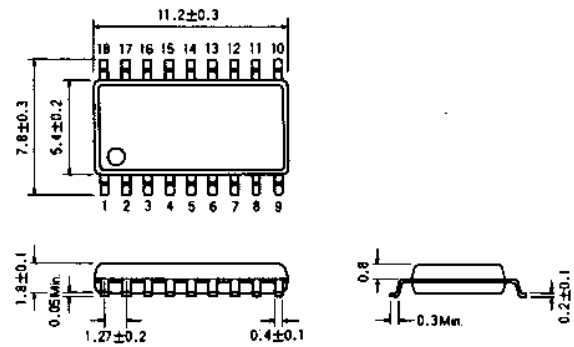

Fig. 2

Block Diagram

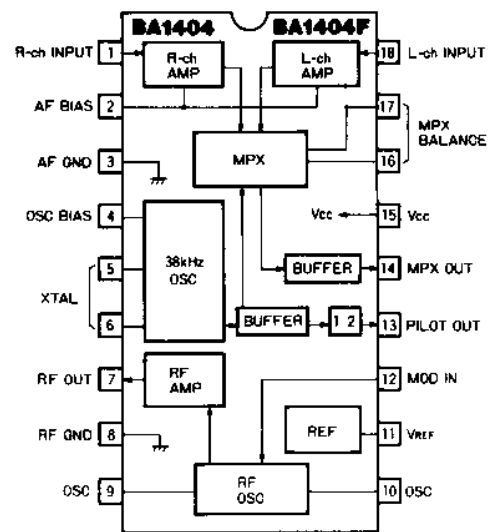

Fig. 3

Absolute Maximum Ratings (Ta=25°C)

Parameter	Symbol	Limits	Unit
Supply voltage	V _{CC}	3.6	V
Power dissipation	P _d	500*	mW
Operating temperature range	T _{opr}	-25 ~ 75	°C
Storage temperature range	T _{stg}	-50 ~ 125	°C

*Derating is done at 5mW/°C for operation above Ta=25°C.

Recommended Operating Conditions

Parameter	Symbol	Min.	Typ.	Max.	Unit	Conditions
Supply voltage	V _{CC}	1	1.25	3	V	—

Electrical Characteristics (Ta=25°C, V_{CC}=1.25V)

Parameter	Symbol	Min.	Typ.	Max.	Unit	Conditions
Quiescent current	I _Q	0.5	3	5	mA	—
Input impedance	Z _{IN}	360	540	720	Ω	f _{IN} = 1kHz
Input gain	G _V	30	37	—	dB	V _{IN} = 0.5mV
Channel balance	CB	—	—	2	dB	V _{IN} = 0.5mV
MPX maximum output voltage	V _{OM}	200	—	—	mV p-p	THD ≤ 3%
MPX 38kHz leakage	V _{OO}	—	1	—	mV	Quiescent condition
Pilot output voltage	V _{OP}	460	580	—	mV p-p	No-load
Channel separation	Sep	25	45	—	dB	with standard demodulator
Equivalent input noise voltage	V _{NIN}	—	1	—	μV rms	IHF-A at 38kHz stop
RF maximum output voltage	V _{OSC}	350	600	—	mV	—

Test Circuit and Application Example

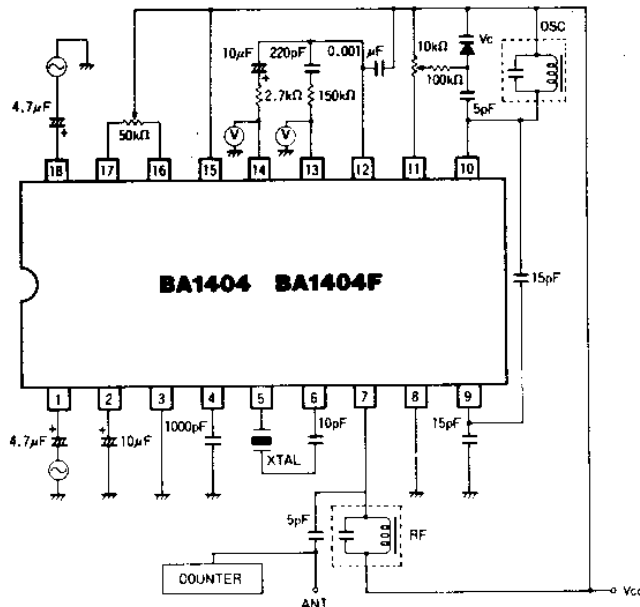

Fig. 4

Coil data (OSC, RF common)	
Bobbin	φ5mm with ferrite core
Coil	φ0.5mm enamel wire
Numbers of turns	2.25 turns
Capacity	47pF

Precautions

1. To match the frequency response of the transmitter with the FM broadcast receiver, use a pre-emphasis network with a time constant of 50 μs at the input of the AF amplifier. Use the following circuit and components:

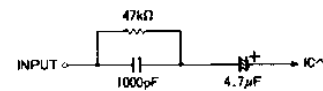

Fig. 5

2. When synthesizing a composite signal from the stereo modulator output with pilot signal, channel separation may deteriorate unless the two signals are in-phase. Note this point if you change the constants of the external components connected to pins 12, 13, and/or 14.

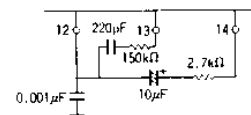

Fig. 6

Precautions

- The carrier for an FM stereo signal can be modulated with an AF signal of up to 19 kHz. If impulse audio input, such as from an electronic musical instrument, is expected, use a low-pass filter at the input of the device to prevent beat interference or deterioration of separation.
- While the device ensures good separation even if the balance control pins (16 and 17) are left open, it provides an even better separation if you connect around 50 kΩ across these pins to optimize the dc balance in the multiplex circuit.

- The output voltage at pin 11 is internally set to $(V_{CC} - 0.7)$ V.

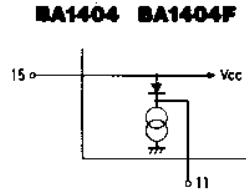

Fig. 7

Electrical Characteristic Curves

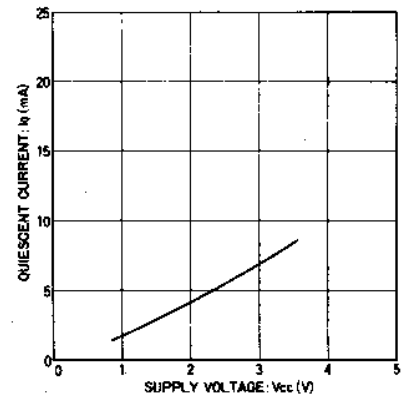

Fig. 8 Quiescent current vs. supply voltage

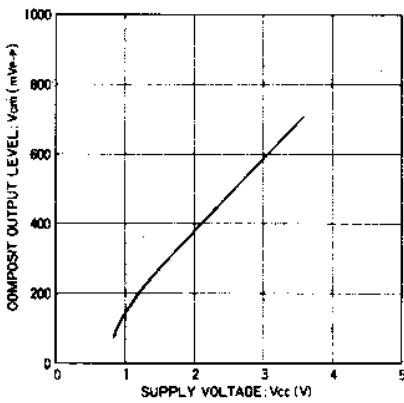

Fig. 9 Composite output level vs. supply voltage

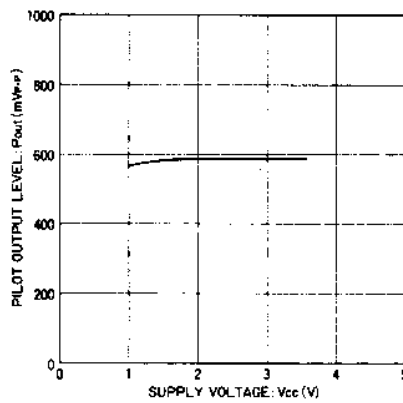

Fig. 10 Pilot output level vs. supply voltage

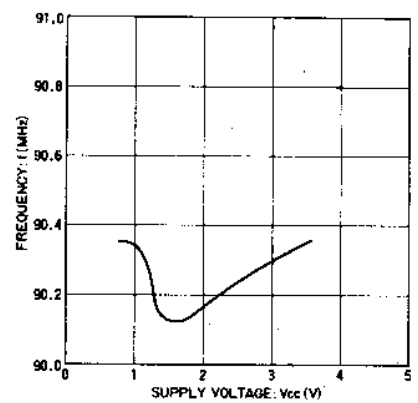

Fig. 11 Frequency vs. supply voltage

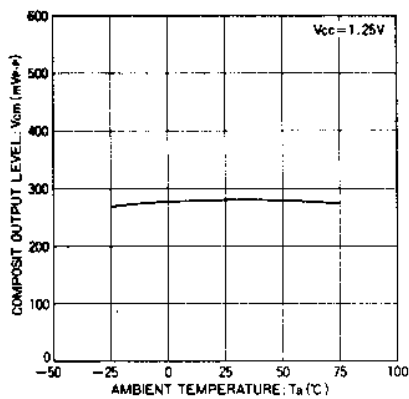

Fig. 12 Composite output level vs. ambient temperature

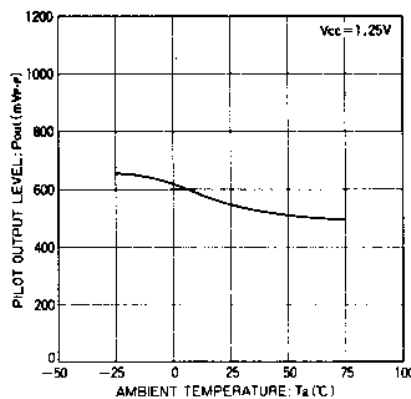

Fig. 13 Pilot output level vs. ambient temperature

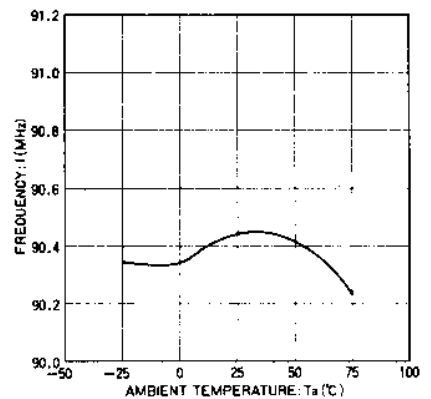
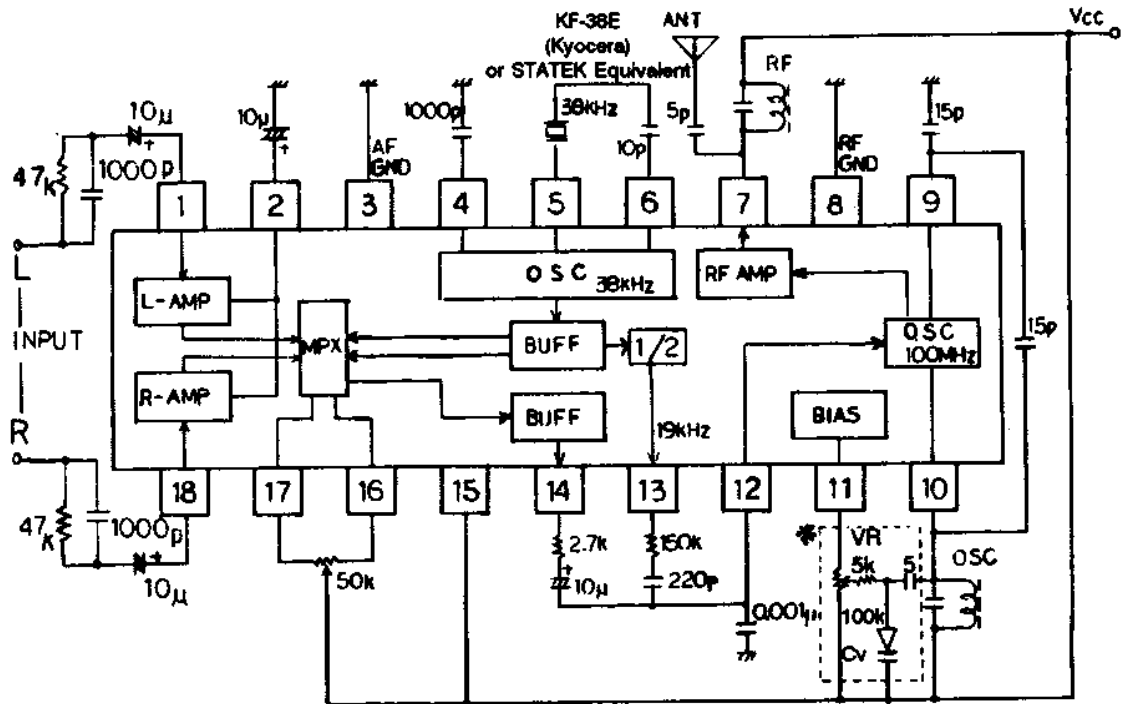

Fig. 14 Frequency vs. ambient temperature



*f₀: Fine adjustment

Application Diagram

Cv: Sanyo SVC 321

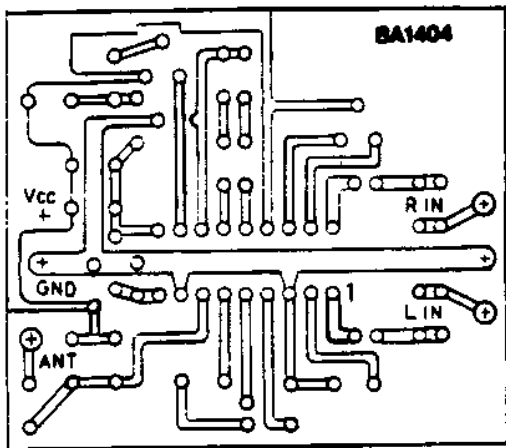

PCB Pattern
(not to scale)

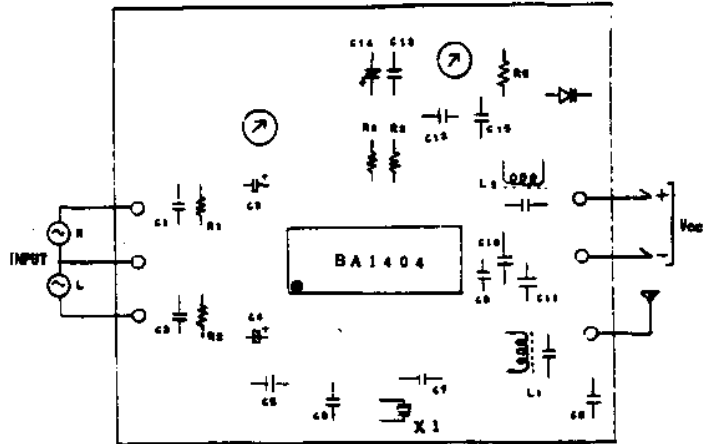

ROHM CORP. reserves the right to make changes to any product herein to improve reliability, function or design. ROHM CORP. does not assume any liability arising out of the application or use of any product described herein, neither does it convey any license under its patent right nor the rights of others.

ROHM CORPORATION · September 1989 · Printed in U.S.A.

ROHM CORPORATION
 8 Whatney
 Irvine, CA 92718
 (714) 855-2131
 (714) 855-0819 (Microsystems)
 FAX: 714-855-1669

SUBJECT: BA1404 SUPPORT.

THE FOLLOWING EXCERPT FROM FREQUENTLY ASKED QUESTIONS IS PROVIDED FOR YOUR SUPPORT.

- 1) **WHAT IS THE UPPER CARRIER FREQUENCY LIMIT? 100 mHz.**
- 2) **WHAT IS THE LOWER FREQUENCY CARRIER LIMIT? 40 mHz.**
THE BA1404 MAY FUNCTION OUTSIDE OF THE ABOVE LIMITS BUT CHARACTERIZATION TESTING AT THE PROPOSED CARRIER FREQUENCY IS REQUIRED.
- 3) **WHAT IS A SUGGESTED MANUFACTURE AND PART NUMBER FOR THE 38 KHZ CRYSTAL? KYOCERA P/N KF-38E.**
- 4) **WHAT IS A SUGGESTED MANUFACTURE AND PART NUMBER FOR THE OSCILLATOR COIL? SUMIDA P/N FEM 10C 2F6.**
- 5) **WHAT IS A SUGGESTED MANUFACTURE AND PART NUMBER FOR THE VARICAP? SANYO P/N SVC-321 FOR THROUGH HOLE AND MATSUSHITA P/N MA321 FOR SURFACE MOUNT.**
- 6) **WHAT IS THE RECOMMENDED ANTENNA LENGTH? 80 CM.**
- 7) **WHAT IS THE RECOMMENDED METHOD TO SET THIS DEVICE UP FOR MONO TRANSMISSION? 4 OPEN, 5 GRND, 6 CONNCT'D, 13 OPEN, 1 INPUT.**
- 8) **IS THE 10K POT CONNECTED TO PIN 11 USED TO TUNE THE TRANSMISSION FREQUENCY? YES.**
- 9) **HOW STABLE IS THE TRANSMISSION FREQUENCY? SEE PAGES 11, 12 AND 13 OF THE APPLICATION NOTE. FREQUENCY DRIFT IS A FUNCTION OF BOTH Vcc AND TEMPERATURE. TO MAINTAIN FREQUENCY DRIFT TO WITHIN +- 100 KHz USE REGULATED Vcc, AN AIR COR COIL AND AN "SH" RANK OSCILLATOR CAPACITOR.**
- 10) **IS THERE A RECOMMENDED METHOD TO DIGITALLY TUNE THE TRANSMISSION FREQUENCY? NO BUT A D/A CONVERTER MAY PROVIDE THIS FUNCTION.**
- 11) **WHAT IS THE TYPICAL PIN 11 VOLTAGE? 0.6 V. TYPICAL**
- 12) **WHAT IS THE TYPICAL PIN 13 VOLTAGE? 0.6 V. TYPICAL**
- 13) **WHAT IS THE TYPICAL PIN 14 VOLTAGE? 0.4 V. TYPICAL**
- 14) **IS THERE A RECOMMENDED BOOSTER/ISOLATION AMPLIFIER FOR CONNECTION BETWEEN THE OUTPUT AND THE ANTENNA? NO**
- 15) **WHAT IS THE FREQUENCY RESPONSE OF THE TRANSMITTED AUDIO SIGNAL?**
- 16) **WHAT IS THE OUTPUT IMPEDANCE OF THE RF AMPLIFIER. 50K OHM MINIMUM.**
- 17) **WHAT IS THE INPUT IMPEDANCE OF PIN 5? 30 K OHM.**
- 18) **WHAT IS THE INPUT IMPEDANCE OF PIN 6? 130 K OHM.**
- 19) **WHAT IS THE FREQUENCY RANGE OF THE OSCILLATOR? 4.5 mHz +- 75 KHz. 70 mHz +- 300 KHz IS RECOMMENDED.**
- 20) **WHERE CAN THIS DEVICE BE PURCHASED?**
OHM ELECTRONICS. 708-359-5500.

THE PRECEDING INFORMATION IS PROVIDED AS AN ENGINEERING GUIDE LINE ONLY.